



Housing Rehabilitation Program
Bid Submission Packet
**Storm Cellar, Tuckpoint, Steel Door, Landing,
&Steps**

Bid Due Date: 12/4/2020 at 2:00 PM
Project Address: 1514 15th street, Rock Island, IL
61201 File Number: TARRP (43-2020)

For questions or assistance, please contact:

Jeff Laxton
Construction Officer
Phone: 309-732-2906
Email: laxton.jeff@rigov.org

For Office Use Only:

Date of Invitation: **11/17/2020**

Bid Opened on: _____ Time: _____ By: _____

Staff to complete this portion after bid opening:

In-House: _____ Contractor Bid: _____ Difference: _____

**City of Rock Island Housing
Rehabilitation Program Bidding
Instructions and Requirements**

GENERAL INSTRUCTIONS:

1. The contractor and subcontractors must meet all applicable State, County, and/or City licensing requirements. The successful bidder will be required to comply with the program's insurance requirements at all times while performing contracted service work.
2. The contractor and subcontractors are required to **visit the project** as part of bid preparation.
3. Contractors must verify all measurements referenced in the work write-up. **No Change Orders will be approved for measurements not verified at the bidding stage.**
4. All work and materials must meet the City of Rock Island guidelines and applicable Federal, State and Local Codes; and must meet HUD and Illinois state requirements including but not limited to employed lead-safe work practices [See 24 CFR, Part 92, 47 I11. Adm. Code, Part 370, and 77 I11. Admin. Code 845].
5. The Contractor's bid shall include all necessary labor, materials, tools, equipment, permits, applicable fees, and all other items necessary to complete the project in conjunction with the work write up/risk assessment.
6. The successful Contractor shall provide satisfactory certificates of insurance evidencing the required insurance coverage, which certificates shall name the Recipient, the City of Rock Island.
7. Each contractor is responsible for completing and submitting a Contractor Information form to the City prior to the awarding of a Housing Rehabilitation Program bid. Completed Contractor Information form may be submitted with your bid. Bids will not be awarded to a non-approved contractor
8. **CANCELLATION OF INVITATIONS FOR BIDS OR REQUESTS FOR PROPOSALS.** An invitation for bids, a request for proposals, or other solicitation may be canceled, or any or all bids or proposals may be rejected in whole or in part as may be specified in the solicitation or otherwise, when it is for good cause or in the best interests of the City. The reasons therefore shall be made part of the contract file. Each solicitation issued by the City shall state that the solicitation may be canceled and that any bid or proposal may be rejected in whole or in part for good cause or when in the best interests of the City as the City, in its sole and exclusive discretion, may determine. Notice of cancellation shall be sent to all businesses solicited, or from whom bids or proposals were received. The notice shall identify the solicitation, explain the reason for cancellation and, where

appropriate, explain that an opportunity will be given to compete on any re-solicitation or any future procurement of similar items. Reasons for rejection shall be provided upon request by unsuccessful bidders or offerors.

9. The City of Rock Island is committed to preserving equal rights for all of its citizens during the construction of its public (works) projects and encourages minority contractors to submit bids for this work. The City also encourages bidders to consider hiring subcontractors and employees of all racial and ethnic backgrounds.
10. The City of Rock Island does not discriminate against any class of protected individuals.

BID INSTRUCTIONS:

1. Submit complete itemization of work on the specification's pages. Telegraphic, electronic mail, facsimile, or other similar forms of bid submission shall not be accepted.
2. The bid must be submitted in **ink or typed** and be clearly written. Bids presented in pencil will not be accepted. Any corrections made when providing pricing must be clearly written and initialed by the bidder. Unclear writing may result in rejection of bid. **Incorrect calculations shall result in rejection of the bid.**
3. In addition to the work write-up, contractors and their subcontractors are encouraged to identify any code violations or recommend corrections that do not appear in the work write-up. The contractor should itemize any additions, **or corrections** (such as measurements), **to the work write-up** on a **separate** sheet and may submit a **separate bid reflecting the additions or corrections.**
4. Contractors **must** guarantee the bid price for a period of sixty (60) days after the deadline date for submission of the bid. Failure to honor submitted bid shall result in removal from the approved contractor list for any future bids.
5. The selected contractor shall attend a Pre-Construction meeting prior to work beginning. Work cannot begin until a Notice to Proceed is issued by the City of Rock Island and the Homeowner.
6. Incomplete bids and those that do not conform to the General Instructions or Bid Instructions may be rejected.
7. The contractor is responsible to make sure all required bid documents are attached to the submitted bid prior to submission.



Specifications

Location: 1514 15th Street Rock Island, IL 61201

Bid Due in City Hall on 12/04/2020 at 2:00 PM

Project Manager: Jeff Laxton, 309-732-2906

Property Owner: William Vanthournout Phone 309-716-2716

Location: Interior				
Specification	Quantity	Units	Unit Price	Total Price
Remove old cellar well. Dig footings and rebar then pour concrete (see attachment). Block up 3 walls with 8x16x8 blocks to floor height (see attached Diagram). Pack ½” J-bolts in top course with mortar. 2x6 green treated bolted down to block. Waterproofing on the outside of the block before the backfill. Permit required.	1			
Install new pre-hung steel door at the bottom of the stairs. Must have dead bolt and new lockset.	1			
Install metal sloped cellar lockable doors. Doors must be weather tight and flashed properly to the house.	1			
Install a set of stairs from the top of opening at grade to the bottom at the basement door. Must be attached to block walls using treated lumber anywhere contact with concrete or block. Stairs maybe cut little taller and shorter run to fit into tighter space. Handrail on one side. Permit required.	1			
Tuckpoint existing foundation in the area’s that old mortar has fallen or is failing.	1			
Build new 6x5 ft landing centered off the sliding door. Steps installed to ground off the rear. Handrail to code. Will need to flash behind new deck and repair area where the old deck was. Weather tight seal in the area of the old deck. Old deck has been removed already. Permit required.	1			
General Requirements				
Specification	Quantity	Units	Unit Price	Total Price
OWNER’S FINISH SELCTIONS The owner shall select finish, colors, styles, and types of materials from pre-mixed, in stock options. The contractor and property owner shall submit to the Planning & Redevelopment Division a copy of the agreed upon colors, styles, and types of materials prior to job start.	NA			
MANUFACTURER’S SPECIFICATIONS PREVAIL All materials shall be installed in full accordance with the manufacturer’s specifications for working conditions, surface preparation, methods, protection, and testing.	NA			



Specifications

Location: 1514 15th Street Rock Island, IL 61201

Bid Due in City Hall on 12/04/2020 at 2:00 PM

Project Manager: Jeff Laxton, 309-732-2906

Property Owner: William Vanthournout Phone 309-716-2716

<p>VERIFY QUANTITIES & MEASUREMENTS All measurements are for the contractor's convenience prior to a mandatory site inspection to verify all dimensions. All quantities are as stated. No claim for additional funds due to discrepancies in measurements or quantities shall be honors if no submitted at the time of the initial proposal.</p>	<p>NA</p>			
<p>ALL PERMITS REQUIRED The contractor shall apply for, pay for, obtain, and forward copies of required permits to the Planning & Redevelopment Division all permits as required by the City of Rock Island Inspections Division. Work to comply with all applicable Rock Island codes and ordinances. Contractor responsible for knowledge of and adherence to such codes and ordinances.</p>				



Specifications

Location: 1514 15th Street Rock Island, IL 61201

Bid Due in City Hall on 12/04/2020 at 2:00 PM

Project Manager: Jeff Laxton, 309-732-2906

Property Owner: William Vanthournout Phone 309-716-2716

<p>CONTRACTOR PRE-BID SITE VISIT The contractor must inspect the property. Submission of a bid is presumptive evidence that the bidder has thoroughly examined the site and is conversant with the requirements of the local jurisdiction.</p>	<p>NA</p>			
<p>WORKMANSHIP STANDARDS All work shall be performed by mechanics both licensed and skilled in their particular trade as well as the tasks assigned to them. Work to adhere to best practices standards of each particular trade and activity. Workers shall protect all surfaces as long as required to eliminate damage. All work to be following latest edition of ICC codes as adopted by the City of Rock Island.</p>	<p>NA</p>			
<p>ONE YEAR GENERAL WARRANTY Contractor shall remedy any defect due to faulty material or workmanship and pay for all damage to other work resulting therefrom, which appears within one year from final payment. Further, contractor shall furnish owner with all manufacturers' and suppliers' written warranties covering items furnished under this contract prior to release of the final payment.</p>	<p>NA</p>			
<p>REMOVAL OF CONSTRUCTION DEBRIS The contractor shall be responsible for removing all construction debris following construction. The contractor shall indicate the specific disposal site and location to which the contractor plans to haul and dispose of debris. For each class of demolition material, the contractor shall provide receipts that the material has been disposed of in accordance with local, state, and federal requirements for permanent disposal. Such receipts shall be submitted with final payment request form.</p>				



Specifications

Location: 1514 15th Street Rock Island, IL 61201

Bid Due in City Hall on 12/04/2020 at 2:00 PM

Project Manager: Jeff Laxton, 309-732-2906

Property Owner: William Vanthournout Phone 309-716-2716

Total Cost	
Company	
Federal Tax ID	
DUNS Number	
Contact Person	
Phone Number	
Email	
Signature	
Date	

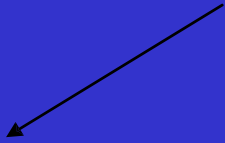

Concrete Encased Grounding

Electrode Required

NEC 252.A.3

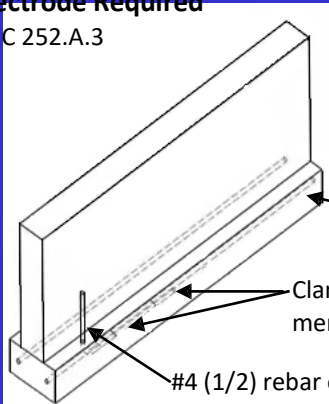

#4 (1/2) Footing rebar
at least 20' in length

Clamp suitable for encase-
ment or exothermic weld

#4 (1/2) rebar or larger

Trench Footing

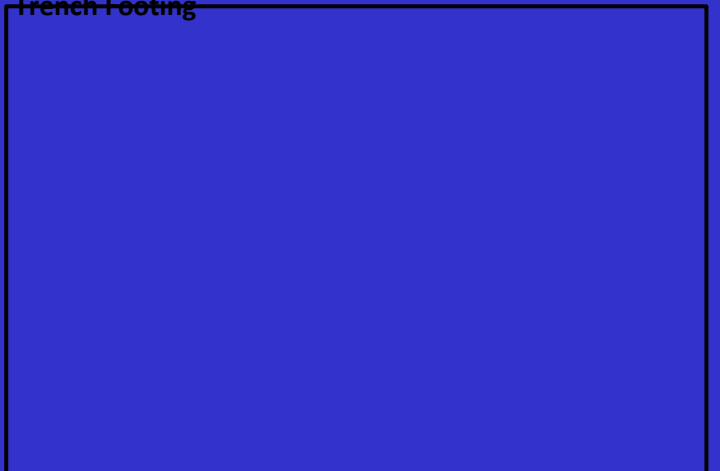

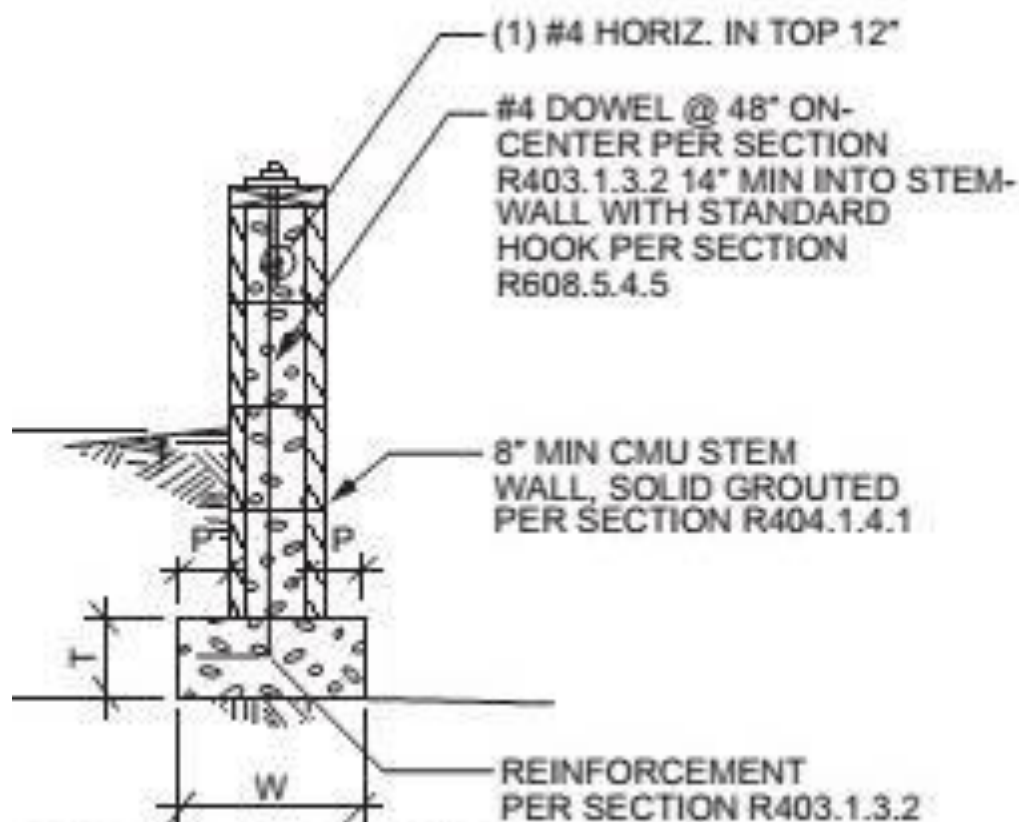

BASEMENT OR CRAWL SPACE WITH MASONRY STEM WALL AND SPREAD FOOTING